

Manual Robot : Worm Robot

Objective

The robot moves like a worm, it is one of the simplest moving actions in the nature. The robot that finishes 2M run with the shortest time is the winner.

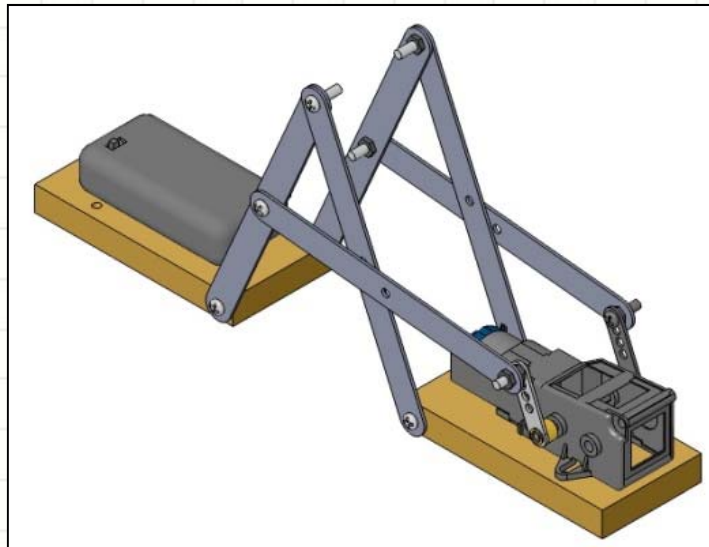

Manual Robot : Worm Robot

Game Field Specification

- Level runway is used for preliminary rounds. The track is 2000 mm long. The starting block is 400mm long.
- The runway has 3 tracks. Each track is 150mm wide.
- A timer is placed at the finish end of each runway.

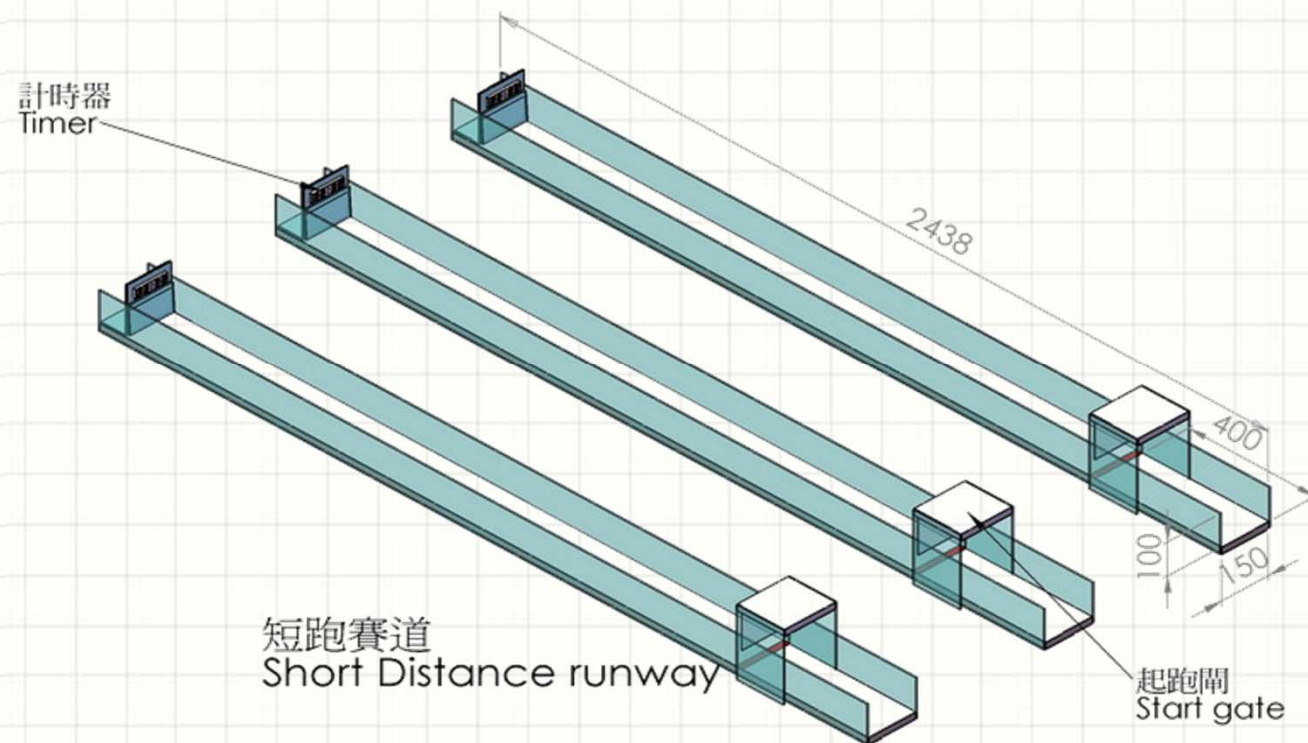

Manual Robot : Worm Robot

Robot Dimensions

- The robot operates only with one motor. Contestants must use the Hand Generator provided by the Organizer to supply power to the robot. Hence, the robot must be equipped with a 2.1mm socket for connection of the Hand Generator.
- The size of the robot cannot exceed 300mm long, 150 mm wide and 180mm tall (length, width and height dimensions are not inter-changeable), nor overall weighs more than 500 g.
- The robot moves by 'contraction and stretch' method and should not use ratchet to assist the motion.
- Only the sole of the feet is allowed to touch the ground. Any other parts of the robot touching the ground are prohibited.
- The robot cannot have any installation that would change its original dimension during competition.

Manual Robot : Worm Robot

Game Rules

- Each team can play twice and the best time will be recorded. The team with the shortest recorded time to complete is the winner.
- Contestants must use the Hand Generator provided by the Organizer to supply power to the robot.
- Pulling the wire of the hand generator is prohibited.
- The wire of the Hand generator is long enough so that the contestants must remain behind at the starting district. Moving along the runway with the robot is prohibited.
- Once the game begins, the contestants cannot touch the walking robots until the game finishes. The maximum game time is 60 seconds. Robots that cannot complete the game would be recorded 60 seconds game time.