

Manual Robot : Triathlon Robot Relay Competition

Objective

This competition involves teams each formed by a set of 3 different robots racing in a triathlon relay. The team that finishes within the shortest time is the winner.

The first part is 2 legs robot short distance run; the second part is ladder climbing; the third part is rod climbing.

Manual Robot : Triathlon Robot Relay Competition

Game Field Specification

- A Triathlon Relay court is used. The maximum outer width of the ladder is 120 mm and inner width is 80 mm.
- An easy hanging device should be designed for the rod climbing robot. Contestants cannot pull out the top bar to hang in the rod climbing robot.

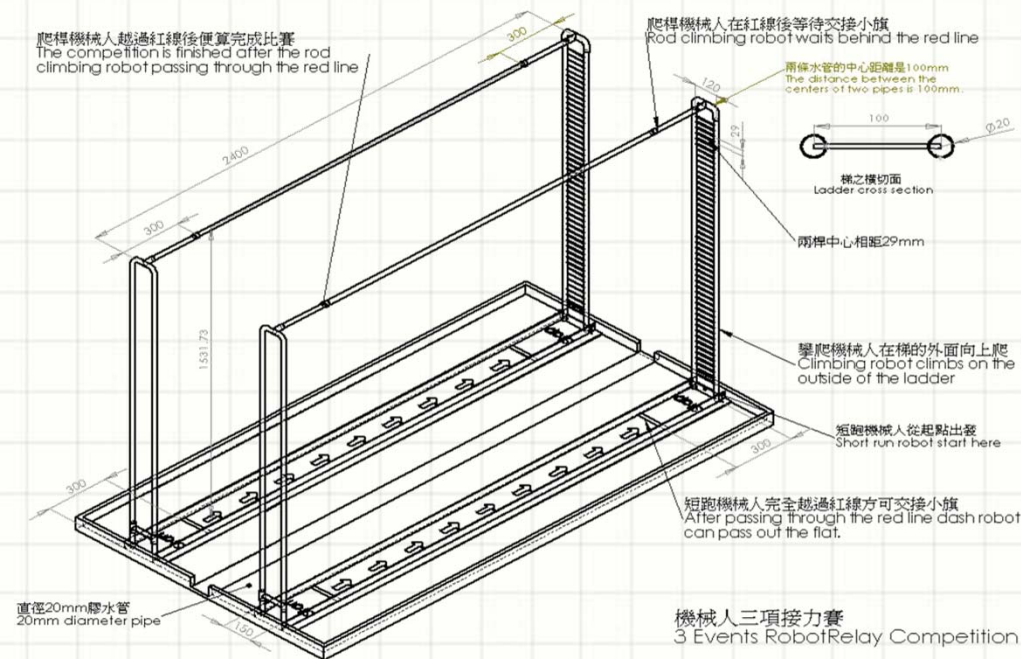

Manual Robot : Triathlon Robot Relay Competition

Robot Dimensions

- Each robot operates only with **one motor**. Contestants must use the Hand Generator provided by the Organizer to supply power to the robot. Only one hand generator is used for all three robots.
- The size of each robot cannot exceed 300mm long, 150mm wide and 180mm tall (length, width and height dimensions are not interchangeable). The gross weight should not exceed 500 g.
- No robot should be powered by wheel actions (or rotate like a wheel) nor auxiliary wheel.
- Robot short distance run must complete the race on 2 legs

Specification of robot short distance run

- The robot operates only with one motor. Contestants must use the Hand Generator provided by the Organizer to supply power to the robot. Hence, the robot must be equipped with a 2.1mm socket for connection of the Hand Generator.
- The size of the robot cannot exceed 300mm long, 150mm wide and 180mm tall (the length, width and height dimensions are not interchangeable), nor overall weighs more than 500g.
- The robot must complete the game in walking mode on 2 legs. No auxiliary parts can touch the ground.
- The robot cannot have any installation that would change its original dimension during competition.

Manual Robot : Triathlon Robot Relay Competition

Robot Dimensions

- No auxiliary parts can touch the ground.
- Each robot must be equipped with a 2.1mm socket for connection of the Hand Generator. The plug of the hand generator can then be unplugged and transferred to another robot during the relay.

Manual Robot : Triathlon Robot Relay Competition

Game Rules

- Each team may have a maximum of **3** members.
- The maximum game time is 3 minutes. The first robot (2 legs short distance running robot) begins from the starting point. Once the front end of the first robot touches the red line at the end of the track, the plug of the hand generator can be unplugged and transferred to the second robot (the ladder climbing robot). The ladder climbing robot starts climbing up on the exterior of the ladder to the top. The plug of the hand generator can be unplugged and transferred to the third robot (the rod climbing robot) when the second robot passes through the red line. When the front end of the rod climbing robot passes through the red line, the game is finished.

Manual Robot : Triathlon Robot Relay Competition

Game Rules

- If a robot fails to move, it can retry from the starting point of that particular race. There is no limit on the number of re-try.
- Each team can play twice and the best time will be recorded. The team with the shortest recorded time to complete is the winner.